



## GENERAL

The **ALVT** is a Vortex flowmeter based on Van Karman theory of vortices generated by a bluff body in the pipe. The number of vortices are linearly proportional to the volumetric flow in the pipe. The ALVT is versatile flowmeter widely used for Gases, Steam & Liquid applications. There are no moving parts. The inline version comes with either flange or wafer version, while the insertion style comes in flange or hot-tapped connections. Standard configuration comes with local display indicating flowrate and total flow. Signal interface includes, 4-20mA, RS485, MODBUS etc. The electronics are designed to filter out erroneous signals as well as noise due pipe vibration.



## FEATURES

- No moving parts, high reliability and durability
- Convenient installation and maintenance
- Non-wetted sensor provides stable performance and long life
- Output pulse signal is proportional to flow rate; high accuracy and no zero drift
- Wide measuring range; turndown ratio of 20:1
- Low pressure loss, low cost
- Frequency output unaffected by changes in fluid media's physical character and composition; meter factor (K) is determined purely by the shape and dimensions of the bluff body. No need to compensate for volume flowrate.
- Meter may be re-calibrated using original K-factor if damaged parts be exchanged.
- Wide array of applications for steam, gasses, liquids

## SPECIFICATION

- Process connections : flanged(standard), Insertion(fixed and adjustable) type, Wafer style
- Process temperature : -30~662 °F (-35~350 °C) without LCD display  
-23~480 °F (-5~250 °C) with LCD display
- Operating pressure : up to 930 psig (64 barg)
- Velocity Range : Depends on fluid, pressure and temperature
- Liquids : ≤0~40 feet/second (0~12m/s)  
Gas & Steam : ≤12 feet/sec (3.5m/s) gas; ≤230 feet/sec (70m/s) steam
- Accuracy : ±1.0% for liquid, ±1.5% for gas, ±2.5% for insertion ty
- Repeatability : ±0.33% for liquid, ±0.5% for gas, ±0.83% for inser
- Turn down ratio : 20:1
- Material : SS #304 (housing) , Carbon Steel (standard flange)
- Signal output : Puls output, Two-wire 4~20mA, RS485, Hart, ModBus
- RAM Back-up : Lithium Battery, 3.6V<sub>DC</sub>
- Housing protection : IP65; IP67; IP68
- Ex-protect Exid II B T4; Exib II C T 4
- Cable: 30' (10M) free for remote version
- weight (approximate) :  
Wafer : 22 lb (10Kg)~ 28lb (12.7 Kg) (to 12" nomina  
Insertion: 33 lbs (15 Kg)  
Notes:-Flange weight contact factory.
- Signal Interface : RS232 & RS485, HART
- Display units : 4 digit rate and 8 digit total
- Keypad : Rate, Total, setup functions
- Power supply : 110/220 V<sub>AC</sub> or isolated 14~36 V<sub>DC</sub>
- NIST traceable : Dependant on fluid media
- Data storage : EPROM storage up to 5 years
- Data logger : Reading, sampling times ≤500 mS

Wafer

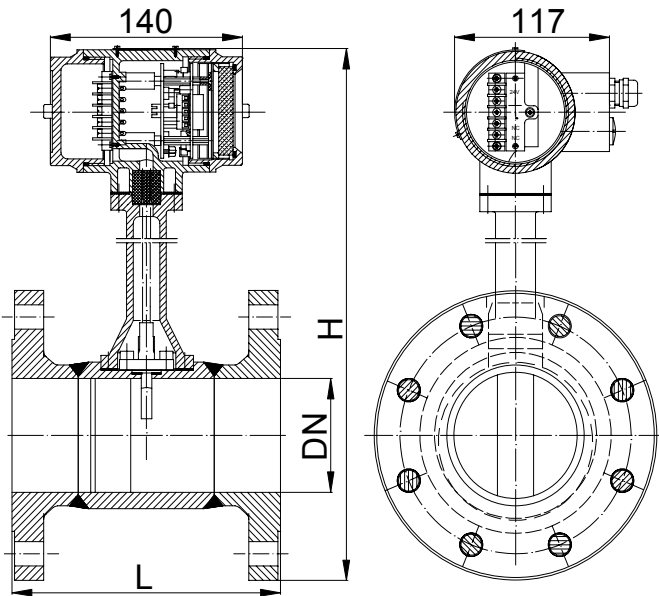

Nom Pipe Size	L ± 1/8"			H ± 1/8"			Weight
	class 150#	class 300#	class 600#	class 150#	class 300#	class 600#	
	1"		7.48	8.66	15.83	16.14	
1 1/4"	5.91	7.87	9.06	16.14	16.42	16.42	24.3 lbs
1 1/2"		7.87	9.45	16.54	16.93	16.93	31.7 lbs
2"	6.69	8.27	9.84	16.93	17.13	17.13	36.4 lbs
2 1/2"	7.48	8.66	10.63	17.72	17.91	17.91	41.9 lbs
3"	7.87	8.66	10.63	18.11	18.50	18.50	51.4 lbs
4"	8.66	9.84	12.60	19.29	20.28	20.16	64.6 lbs
5"	9.45	10.83	14.17	20.28	21.34	21.81	66.8 lbs
6"	10.63	12.20	15.35	21.34	23.23	22.83	23.5 lbs
8"	12.20	13.19	17.72	23.62	24.41	25.20	66.4 lbs
10"	14.57	15.35	20.08	25.87	25.20	27.95	240.3 lbs
12"	15.75	16.93	21.65	28.46	27.17	29.92	258.8 lbs

Insertion - with ball valve

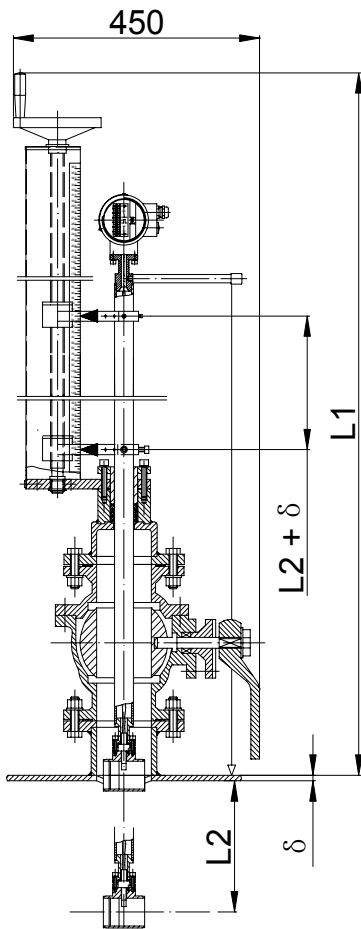

Pipe Size	L1 ± 1/8"	L2	Weight
10"~28"	1570	0.5 d	39.7 lbs
32"~72"	1570	0.121 d	79.4 lbs

Insertion - fixed

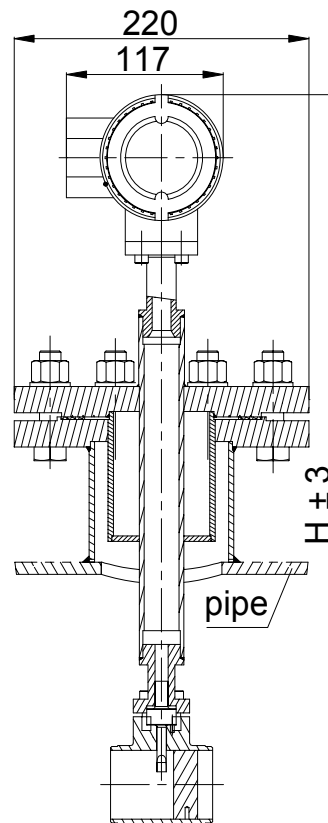

Pipe Size	H ± 1/8"	Weight
10"~28"	D/2 + 14.5	39.7 lbs
32"~72"	0.121 d + 14.5 + δ	79.4 lbs

D is outside diameter of pipe.

d is inside diameter of pipe.

δ is thickness of pipe.

Note: all dimensions are mm unless stated.

Mass flow of saturated steam (tons/hr) unless otherwise r

ID(in.)	29 psi (2 bar)		58 psi (4 bar)		87 psi (6 bar)		116 psi (8 bar)		bar)		bar)		203 psi (14 bar)		232 psi (16 bar)	
½"	15.4-102.3 lbs/h		19.4-165.3 lbs/h		22.9-227.1		25.6-288.1 lbs/h		28.2-349 lbs/h		30.2-409.6 lbs/h		32.8-470 lbs/h		34.8-529.1 lbs/h	
¾"	28.2-181.9 lbs/h		35.7-293.9 lbs/h		42.1-403.7		47.4-512.3 lbs/h		52.5-620.4		57.5-728.2 lbs/h		62.2-835.8 lbs/h		67-943.1 lbs/h	
1"	35.7-284 lbs/h		45.2-459 lbs/h		53.1-630.7		59.7-800.5 lbs/h		66.1-969.2		71.4-1137.8		76.7-1305.8		82-1517.7 lbs/h	
1 ¼"	58-465.4 lbs/h		73.4-752.2 lbs/h		86.4-1033.5		97.9-1311.5		83.8-1588 lbs/h		0.06	0.94	0.06	1.07	0.07	1.21
1 ½"	70.5-727.1 lbs/h		89.5-1175.3		105.2-1614.9 lbs/h		0.06	1.03	0.07	1.25	0.07	1.46	0.07	1.68	0.08	1.88
2"	0.04	0.57	0.07	0.91	0.08	1.26	0.10	1.60	0.11	1.94	0.12	2.27	0.13	2.61	0.14	2.94
2 ½"	0.09	0.96	0.11	1.55	0.13	2.13	0.15	2.70	0.17	3.27	0.17	3.85	0.18	4.41	0.20	4.98
3"	0.13	1.46	0.15	2.35	0.18	3.23	0.20	4.10	0.22	4.96	0.24	5.82	0.26	6.69	0.29	7.54
4"	0.20	2.27	0.25	3.67	0.30	5.05	0.33	6.40	0.36	7.72	0.40	9.10	0.43	10.45	0.45	11.78
5"	0.34	3.55	0.45	5.74	0.56	7.88	0.67	10.01	0.79	12.13	0.94	14.22	1.07	16.33	1.18	18.42
6"	0.44	4.92	0.56	8.27	0.66	11.35	0.78	14.41	0.93	17.45	1.19	20.48	1.38	23.50	1.53	26.52
8"	0.93	9.09	1.17	14.69	1.38	20.18	1.57	25.62	1.81	31.02	2.06	36.41	2.35	41.79	2.63	47.16
10"	1.66	14.20	2.12	22.95	2.49	31.54	2.80	40.02	3.13	48.50	3.56	56.89	3.87	65.29	4.18	73.68
12"	2.39	20.45	3.04	33.06	3.56	45.41	4.01	57.63	4.42	69.78	4.95	81.91	5.49	94.02	6.02	106.10
14"	3.25	27.83	4.13	45.00	4.84	61.82	5.46	78.44	6.01	94.97	6.74	111.55	7.47	127.98	8.15	144.40
16"	4.25	36.35	4.03	58.76	6.32	80.74	7.12	102.46	7.85	124.01	8.80	145.61	9.76	167.11	10.64	188.60
18"	5.37	46.01	6.81	74.37	7.99	102.19	9.01	129.63	9.93	156.97	11.02	184.30	12.35	211.53	13.45	238.76
20"	6.62	56.77	8.40	91.82	9.87	126.21	11.02	160.05	12.26	193.78	13.56	227.51	15.32	261.13	16.60	294.76

Note: The pressures in the above table are gauge pressure

Mass flow of superheated steam (tor

Volumetric flow of gas (SCFM)

Volumetric flow of liquid (GPM)

ID (in.)	min flow	max flow
½"	11.92√ρ lbs/h	63.1 ρ lbs/h
¾"	21.81√ρ lbs/h	112.1 ρ lbs/h
1"	27.57√ρ lbs/h	175.2 ρ lbs/h
1 ¼"	44.92√ρ lbs/h	287.1 ρ lbs/h
1 ½"	54.92√ρ lbs/h	448.6 ρ lbs/h
2"	81.90√ρ lbs/h	700.9 ρ lbs/h
2 ½"	144.97√ρ lbs/h	1184.5 ρ lbs/h
3"	220.00√ρ lbs/h	1794.3 ρ lbs/h
4"	0.15√ρ	1.40 ρ
5"	0.24√ρ	2.20 ρ
6"	0.34√ρ	3.15 ρ
8"	0.72√ρ	5.58 ρ
10"	1.16√ρ	8.76 ρ
12"	1.49√ρ	12.62 ρ
14"	2.03√ρ	17.17 ρ
16"	2.65√ρ	22.43 ρ
18"	3.35√ρ	28.38 ρ
20"	4.16√ρ	35.04 ρ

ID (in.)	min flow	max flow
½"	3.10k / √ρ	17.0k
¾"	5.51k / √ρ	30.0k
1"	7.91k / √ρ	1.3k
1 ¼"	11.58k / √ρ	76.6k
1 ½"	14.02k / √ρ	120.1k
2"	23.24k / √ρ	187.2k
2 ½"	35.14k / √ρ	316.1k
3"	53.33k / √ρ	478.9k
4"	83.34k / √ρ	748.7k
5"	130.0k / √ρ	1,169.6k
6"	186.1k / √ρ	1,684.5k
8"	332.7k / √ρ	2,994.7k
10"	520.2k / √ρ	4,679.2k
12"	748.7k / √ρ	6,738.0k
14"	1,019.2k / √ρ	9,167.7k
16"	1,331.4k / √ρ	11,975k
18"	1,684.9k / √ρ	15,150k
20"	2,080.0k / √ρ	18,713k

ID (in.)	min flow	max flow
½"	52.88 / √ρ	14.13
¾"	93.26 / √ρ	24.88
1"	146.19 / √ρ	38.88
1 ¼"	469.40 / √ρ	63.72
1 ½"	588.73 / √ρ	99.56
2"	735.36 / √ρ	155.57
2 ½"	996.92 / √ρ	262.88
3"	1,510.8 / √ρ	398.19
4"	2,360.2 / √ρ	622.19
5"	3,688.7 / √ρ	972.26
6"	5,312.2 / √ρ	1,399.8
8"	9,444.3 / √ρ	2,488.8
10"	14,757 / √ρ	3,888.6
12"	21,250 / √ρ	5,599.7
14"	28,923 / √ρ	7,621.9
16"	37,766 / √ρ	9,955.1
18"	47,806 / √ρ	12,599
20"	59,030 / √ρ	15,555

Note: ρ = density of the superheated steam under operating condition (Kg/m<sup>3</sup>)

Note: 1. ρ---- density of gas under operating condition (Kg/m<sup>3</sup>)

Note: 1. ρ----density of liquid under operating condition (g/cc)

2. Standard conditions: 70 °F, 14.7 psia (absolute pressure), or under atmosphere at 70 °F

2. Density of water under normal temperature and pressure is 1.0 g/cc.

3. √ρ = 31.623 g/cc

$$k = \frac{P+0.101325}{0.101325} \times \frac{293.15}{t+273.15}$$

**\*\* Please contact your local SMC application engineer**

You also need to provide the following information:

Type of Fluid (liquid/gas or steam)	Please provide the name of your fluid, including operating density and viscosity
Full Scale Flow	Please indicate maximum and minimum flow rates, in units of Kg/hr, Lb/hr, LPM or GPM, etc.
Line Size	Please specify pipe size as well connection type (flange, threaded, etc..)
Process Pressure and Temperature	We will calibrate your flowmeter as close to your operating conditions as possible
Type of Electronics	Please specify either integral or remote electronics
Power Requirements	Specify your power requirements ( 24 V <sub>DC</sub> or 115 V <sub>AC</sub> or 230 V <sub>AC</sub> )

**Model Selection Guide**

ALVT meters													
Example:ALVT-23-15D-11N-IN (0-20,000 kg/hr)													
ALVT-	**	**	_ **	**	_ **	**	**	_ **	**	**	_ **	**	Description
Flanged	1											Style	
Wafer	2												
Insertion- fixed	3												
Insertion- with ball valve mounting assembly	4												
Liquid	2											Fluid	
Gas	3												
Steam	4												
½" (15mm)			015									Line Size	
¾" (20mm)			020										
1" (25mm)			02										
1 ¼" (32mm)			03										
1 ½" (40mm)			04										
2" (50mm)			05										
2 ½" (65mm)			06										
3" (80mm)			08										
4"-57" (100mm-1500mm)			**										
With digital display (standard only)			D									Display	
No display			N										
24V <sub>DC</sub>			1									Power Supply	
3.6V lithium battery			2										
Dual power supply (24V <sub>DC</sub> , 3.6V lithium battery)			3										
No output			0									Signal Output	
Pulse output			1										
Two wire 4-20mA DC output			2										
Three wire 4-20mA DC output			3										
RS-485 Communication			4										
Hart Communication			5										
Standard -40~480 °F (-40~250 °C)			N									Fluid Temperature	
High Temp 480~660 °F (250~350 °C)			H										
230 psig (16 bar)			1									Pressure	
360 psi (25 bar)			2										
580 psi (40 bar)			3										
930 psi (64 bar)			4										
Non			N									Explosion - Proof	
Explosive Isolated			G										
Intrinsically safe			B										
<b>Flow range</b>												Flow rate	